

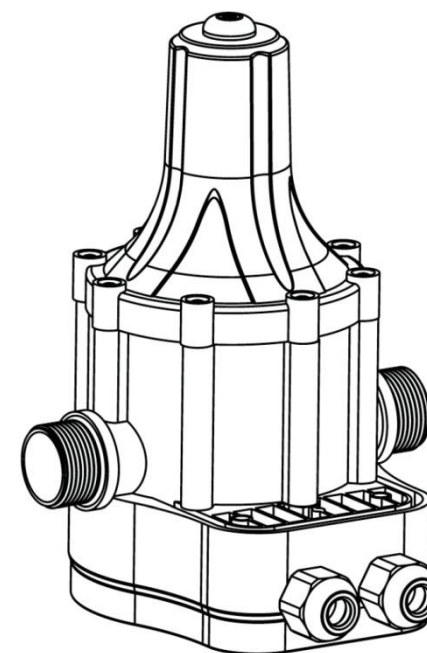

# Automatic Switch

## Instruction Manual



• PS-04A

LEO GROUP PUMP(ZHEJIANG) CO.,LTD.

Add: No.1,3rd Street, East Industry Center 317500

Wenling City, Zhejiang P.R.China

Tel: 0086-576-89986360

Fax: 0086-576-89989898

Email:export@leogroup.cn

www.leogroup.cn

## SPECIFICATIONS

MODEL	PS-04A	PS-04A
RATED VOLTAGE	110V	220-240V
FREQUENCY	60Hz	50/60Hz
MAX. CURRENT	10A	10A
MAX. POWER	1.1kW	1.1kW
MAX. OPERATING PRESSURE	10bar	10bar
CONNECTION THREAD	G1"	G1"
PROTECTION CLASS	IP65	IP65
MAX. OPERATING TEMPERATURE	60°C	60°C
CABLE REQUIREMENT	Cable diameter7.5-9mm	Cable diameter7.5-9 mm

## OPERATION

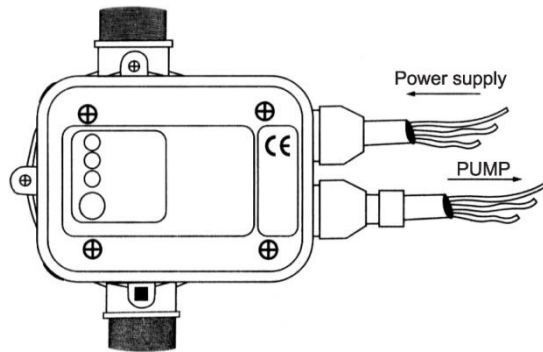

Follow the wire diagrams on the back of the box to make correct connections. Incorrect connections may damage the circuit board. The outer diameter of the 3-core cable shall be between 6 mm and 9 mm. To ensure the water tightness of the control box, all screws and bolts must be tightened.

### STARTING

Upon the unit is connected to the power supply, the button "Power On" becomes green and the button "Pump On" becomes yellow. The pump is ready for operation.

The pump keeps running for a few seconds to charge pressure in the pipe system till the required pressure is reached. In case the pressure cannot be reached, the button "Failure" will become red in a few seconds. Open the tap and keep the button "Reset" pressed till the "Failure" light goes out.

The pump will be shut down by the unit when the max pressure is reached inside the pump in condition the button "Reset" is released and the tap is closed.

### FUNCTION

The unit is programmed to control all pump operations automatically. Some malfunctions can be detected by the unit, such as insufficient water supply and blocked inlet. In this case the button "Failure" becomes red and the pump is stopped by the unit to avoid pump damage caused by dry running.

Restart the unit by pressing the button "Reset" after the malfunction is fixed.

This appliance can be used by children aged from 8 years and above and persons with reduced physical, sensory or mental capabilities or lack of experience and knowledge if they have been given supervision or instruction concerning use of the appliance in a safe way and understand the hazards involved.

Children shall not play with the appliance. Cleaning and user maintenance shall not be made by children without supervision.

### Attention!

If the appliance or the supply cord is damaged, it must be repaired by manufacturer, its service agent or qualified person.



Meaning of crossed -out wheeled dustbin:

Do not dispose of electrical appliances as unsorted municipal waste, use separate collection facilities.

Contact your local government for information regarding the collection systems available.

# INSTALLATION

If the distance between the pump and the tap is more than 15 m, it is not allowed to install the unit in the pump directly. The position of the unit has to be adjusted to make sure that distance is within 15 m.

For example: If the vertical distance between the pump and the tap is 20 m, the unit must be installed vertically upward 5 m far from the pump.

Note: The distance of 15 m is for the unit with starting pressure setting of 1.5 bar. For 2.2 bar, the distance limit is 22 m

The unit is equipped with a check valve to prevent the pipeline from losing pressure.

Do not install any taps between the pump and the unit.

The restarting pressure is 1.5 bar, which is preset by the manufacturer. Normally, the pump pressure shall be at least 0.5 bar higher than the preset pressure.

Before starting, check the inlet pipe and ensure the pump is primed.

It is advisable to connect the unit outlet to the system by means of a flexible hose.

Safety valve prevents water emission in case of diaphragm break

DO NOT TOUCH

Install the unit in accordance with the arrow direction.

The unit can be installed directly on the pump, or between the pump and the first tap.

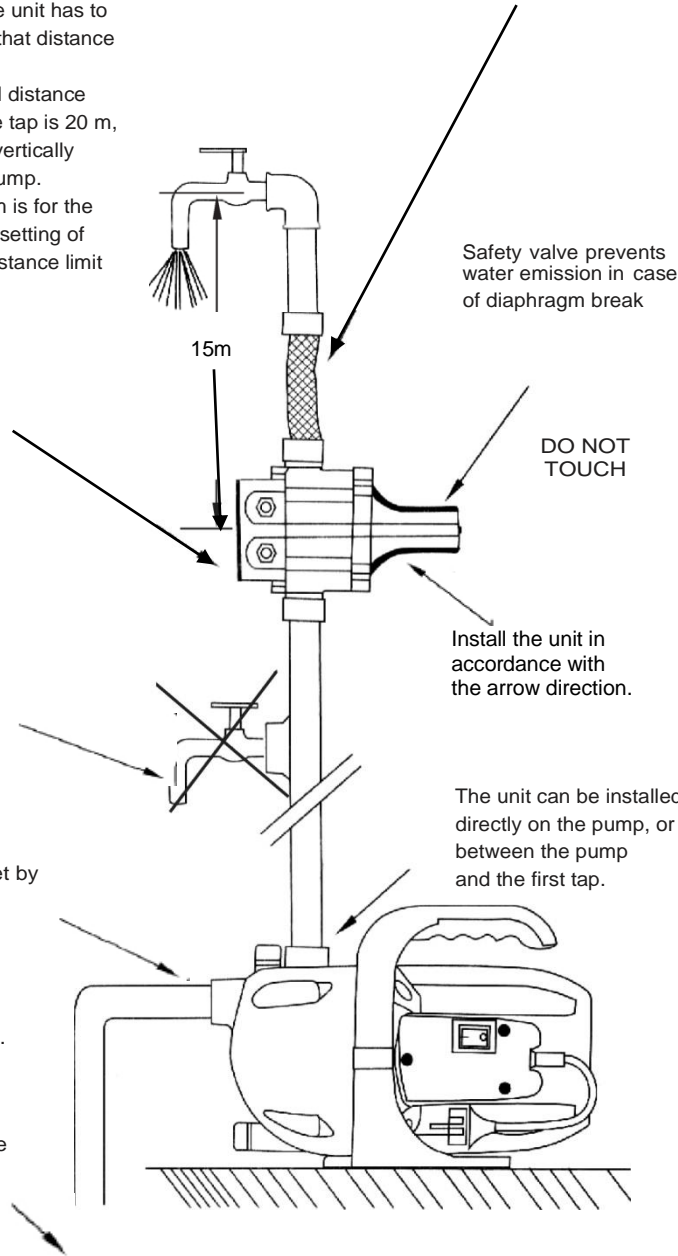

# WIRING DIAGRAM

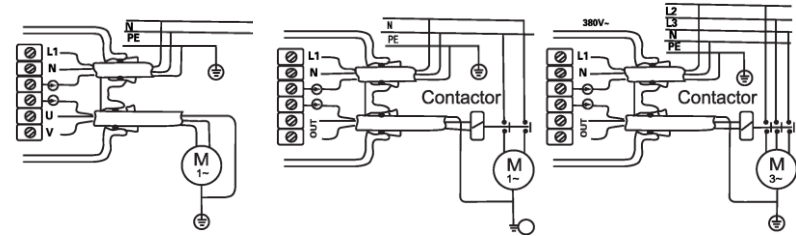

For single phase 220 V/110 V. Power up to 1.1 kW.

For single phase 220 V/110 V with contactor. Power above 1.1 kW.

For three phase 380 V with contactor.

Specifications of the contactor: 220 V/110 V, With minimum power of 4 kW (5.5 HP).

Specifications of the contactor: 220 V/110 V, With minimum power of 4 kW (5.5 HP).

# TROUBLESHOOTING

Phenomena	Possible causes (switch)	Possible causes (other than switch)
The pump does not start	-The circuit board is damaged	-The voltage is too low -The pump is clogged -The connection of cable or motor is wrong
The pump does not stop	-The circuit board is damaged -The flow detector is blocked -The reset button is damaged -The pump pressure is not sufficient	-Pump leakage higher than 0.6 l/min
The pump works intermittently	-The circuit board is damaged -The pump pressure is not sufficient	-Pump leakage lower than 0.6 l/min
The pump is clogged	-The circuit board is damaged -The pump pressure is lower than the restarting pressure	-Water supply is not sufficient -Inlet pipe is blocked