



Application

- Can be used to transfer clean water or other liquids similar to water in physical and chemical properties
- Suitable for lifting water from the well, sprinkling irrigation in garden, pressure boosting of running water, and supporting equipment etc.

Pump

- Cast iron pump body and support under special anti-rust treatment
- Stainless steel impeller
- AISI 304 shaft
- Max. liquid temperature: +60°C
- Max. suction: +9 m

Motor

- Low noise&Long life bearing
- Motor with copper winding
- Built-in thermal protector for single phase motor
- Insulation class: F
- Enclosures class: IPX4
- Max.ambient temperature: +50 °C

Identification Codes

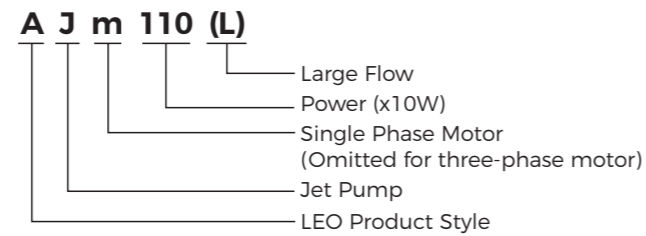

Technical Data

Model	Power		Q(m ³ /h)	H (m)																
	kW	HP		0	0.6	0.9	1.2	1.5	1.8	2.1	2.4	2.7	3	3.6	4.2	4.8	6.0	7.5	8.4	
AJm110H	1.1	1.5	0	60	50	46	44	42	40	38	36	34	32	30	28	-	-	-	-	
AJm150H	1.5	2	10	72	65	61	59	57	54	51	48	45	43	39	34	-	-	-	-	
AJ(m)220H	2.2	3	15	85	78	75	71	68	65	63	60	57.5	55	51.5	46	-	-	-	-	
AJm110	1.1	1.5	20	55	52	49	48	46	45	43	42	41	40	37	35	33	27	-	-	
AJm150	1.5	2	25	60	56	55	53	52	49	48	46	45	44	42	40	36	33	-	-	
AJ220	2.2	3	30	68	67.5	67	66	65	63	61	59	57	56	54	51	48	44	-	-	
AJm110L	1.1	1.5	35	47	45	44	43	42	41	40	39	38	36	34	32	30	24	17	9	
AJm150L	1.5	2	40	54	53	52	51	49	48	46	45	44	43	42	39	38	34	31	26	
AJ220L	2.2	3	45	55	54	53	52	51.5	51	50.5	49.5	49	48	47	45	44	41	38	36	

Dimension

Model	DN1	DN2	L (mm)	W (mm)	H (mm)	L1 (mm)	W1 (mm)	H1 (mm)
AJm110H	1 1/4"	1 1/4"	512	206	236	153	165	112
AJm150H			512	206	236	153	165	112
AJ(m)220H			512	206	236	153	165	112
AJm110			512	206	236	153	165	112
AJm150	1 1/2"	1 1/2"	512	206	236	153	165	112
AJ220			512	206	236	153	165	112
AJm110L			512	206	236	153	165	112
AJm150L			512	206	236	153	165	112
AJ220L			512	206	236	153	165	112

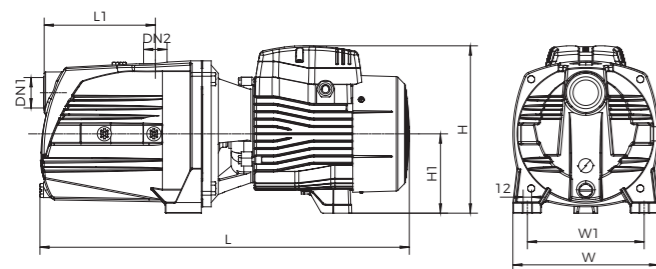

Hydraulic Performance Curves

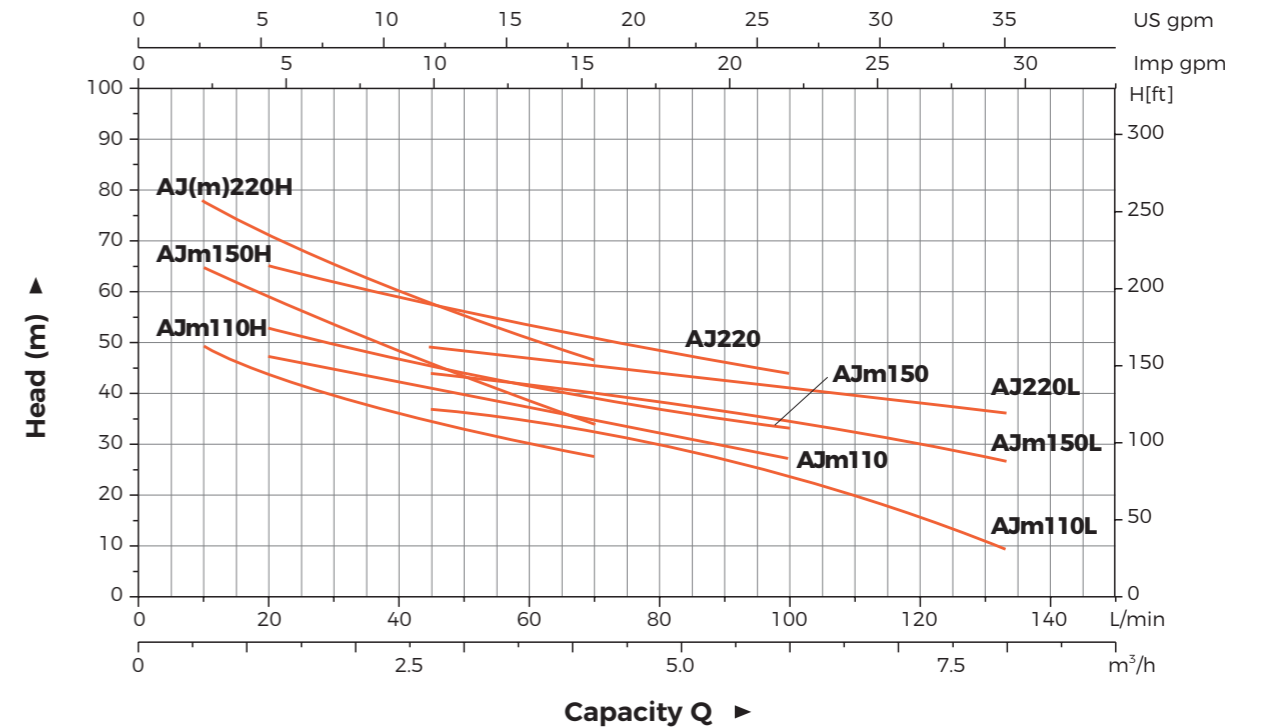

Material Table

No.	Part	Material	No.	Part	Material
1	Pump body	HT200	12	End plate	ADC12
2	Nozzle	PP-GF30	13	Stator	
3	Lance tube	PP-GF30	14	Cover box	PP-GF20
4	Water outlet cover	PP-GF30	15	Capacitor	
5	Impeller	PP-GF30	16	Wiring base assembly	PC
6	Mechanical seal		17	Bearing	
7	O-ring	NBR	18	Rotor	
80	Bracket cover	HT200			
9	Bracket	ADC12			
10	Fan cover	PP			
11	Fan	PP-GF10			

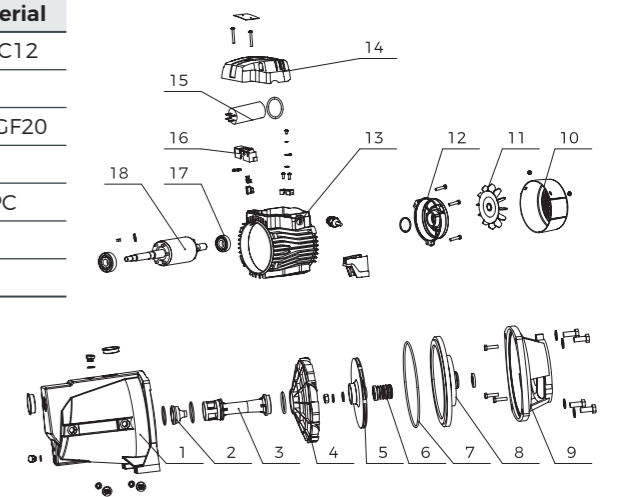

Package Information

Model	GW (Kgs)	L (mm)	W (mm)	H (mm)	Quantity (PCS/20'TEU)
AJm110	24.5	572	225	259	816
AJm110H	24.5	572	225	259	816
AJm110L	24.5	572	225	259	816
AJm150	25.4	572	225	259	816
AJm150H	25.4	572	225	259	816
AJm150L	25.4	572	225	259	816
AJ(m)220H	26.0	572	225	259	816

